

Maxeon 3

SPR- X22-XXX-COM

Commercial Solar Panel

470–485 W | Up to 22.4% Efficient



Ideal for commercial applications



White backsheet, silver frame

More Lifetime Energy

Designed to maximise energy generation through leading efficiency, enhanced performance in high temperatures, and higher energy conversion in low-light conditions like mornings, evenings and cloudy days.

Uncompromising Durability

Engineered to power through all types of weather conditions with crack-resistant cells and reinforced connections that protect against fatigue and corrosion, to an electrical architecture that mitigates the impact of shade and prevents hot-spot formation.



Superior Sustainability

Clean ingredients, responsible manufacturing, and lasting energy production for 40 years make Maxeon panels the most sustainable choice in solar.



The Industry's Longest Warranty

Maxeon panels are covered by a 40-year warranty¹ backed by extensive third-party testing and field data from more than 50 million panels deployed worldwide.

	Installed by a Maxeon Partner	Standard
Product coverage (years)	40	25
Performance coverage (years)	40	25
Service coverage (years)	40	N/A
Minimum warranted output in Year 1		99.0%
Maximum annual degradation		0.40%

maxeon

Learn more about Maxeon panels
maxeon.com/us



Maxon 3 POWER: 470–485 W | EFFICIENCY: Up to 22.4%

Electrical Data		
	SPR-X22-485-COM	SPR-X22-470-COM
Nominal Power (Phom) ²	485 W	470 W
Power Tolerance	+5/0%	+5/0%
Panel Efficiency	22.4%	21.7%
Rated Voltage (Vmpp)	78.8 V	77.6 V
Rated Current (Imp)	6.16 A	6.06 A
Open-Circuit Voltage (Voc) (+/-3%)	92.7 V	91.5 V
Short-Circuit Current (Isc) (+/-3%)	6.55 A	6.45 A
Max. System Voltage	1500 V UL & 1500 V IEC	
Maximum Series Fuse	15 A	
Power Temp Coef.	-0.27% / °C	
Voltage Temp Coef.	-0.236% / °C	
Current Temp Coef.	0.058% / °C	

Certifications and Compliance	
Standard Tests ³	UL 61730, IEC 61215, IEC 61730
Quality Management Certs	ISO 9001:2015, ISO 14001:2015
Ammonia Test	IEC 62716
Desert Test	IEC 60068-2-68, MIL-STD-810G
Salt Spray Test	IEC 61701 (maximum severity)
PID Test	1500 V: IEC 62804
Available Listings	UL, TUV, CEC
IFLI Declare Label	First solar panel labeled for ingredient transparency and LBC-compliance. ⁴
Cradle to Cradle Certified™ Silver	First solar panel line certified for material health, water stewardship, material reutilization, renewable energy & carbon management, and social fairness. ⁵
Green Building Certification Contribution	Panels can contribute additional points toward LEED and BREEAM certifications.
EHS Compliance	RoHS, ISO 45001:2018, Recycle Scheme, REACH SVHC-163

Operating Condition And Mechanical Data	
Temperature	-40°F to +185°F (-40°C to +85°C)
Solar Cells	128 Monocrystalline Maxon Gen 3
Tempered glass	0.13 in (3.2 mm), high-transmission tempered anti-reflective
Junction Box	IP-68, EVO2, 3 bypass diodes
Weight	56 lbs (25.4 kg)
Max. Load ⁶	Wind: 75 psf, 3600 Pa, 367 kg/m ² front & back Snow: 112 psf, 5400 Pa, 550 kg/m ² front
Impact Resistance	1.77 inch (45 mm) diameter hail at 68.7 mph (30.7 m/s)
Frame	Class 2 silver anodized

Packaging Configuration	
Number of modules per pallet	40
Number of pallets per 40ft HQ container	11
Number of modules per container	440

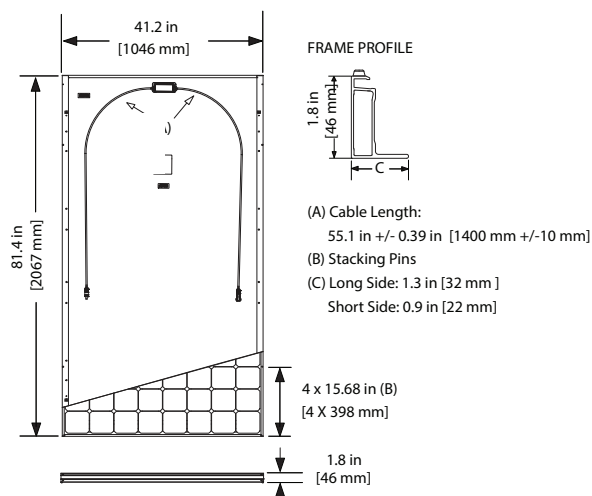

Please read the safety and installation instructions. Visit www.maxon.com/us/InstallGuideUL. Paper version can be requested through technicalsupport.na@maxeon.com.

¹ 40-year warranty terms are not available in all countries or in all installations. In the United States, 40-year warranty terms require digital warranty registration and installation by an authorized Maxon Partner. Please refer to our published warranty documents or contact us for more information.

² Standard Test Conditions (1000 W/m² irradiance, AM 1.5, 25° C). NREL calibration Standard: SOMS current, LACCS FF and Voltage.

³ Type 2 fire rating per UL 61730, Class C fire rating per IEC 61730

⁴ Maxon DC panels first received the International Living Future Institute Declare Label in 2016.

⁵ Maxon DC panels are Cradle to Cradle Certified™ Silver -

www.c2ccertified.org/certified-products-and-materials/maxon-solar-panels. Cradle to Cradle Certified™ is a certification mark licensed by the Cradle to Cradle Products Innovation Institute.

⁶ As per IEC 61215-2016 tested. See Safety and Installation Guideline for details.

Made in Malaysia (Cells)

Assembled in Mexico (Module)

Specifications included in this datasheet are subject to change without notice.

©2024 Maxon Solar Technologies. All Rights Reserved.

View warranty, patent and trademark information at maxeon.com/legal.

maxeon

552489 REV B / LTR_US
Publication Date: March 2024